

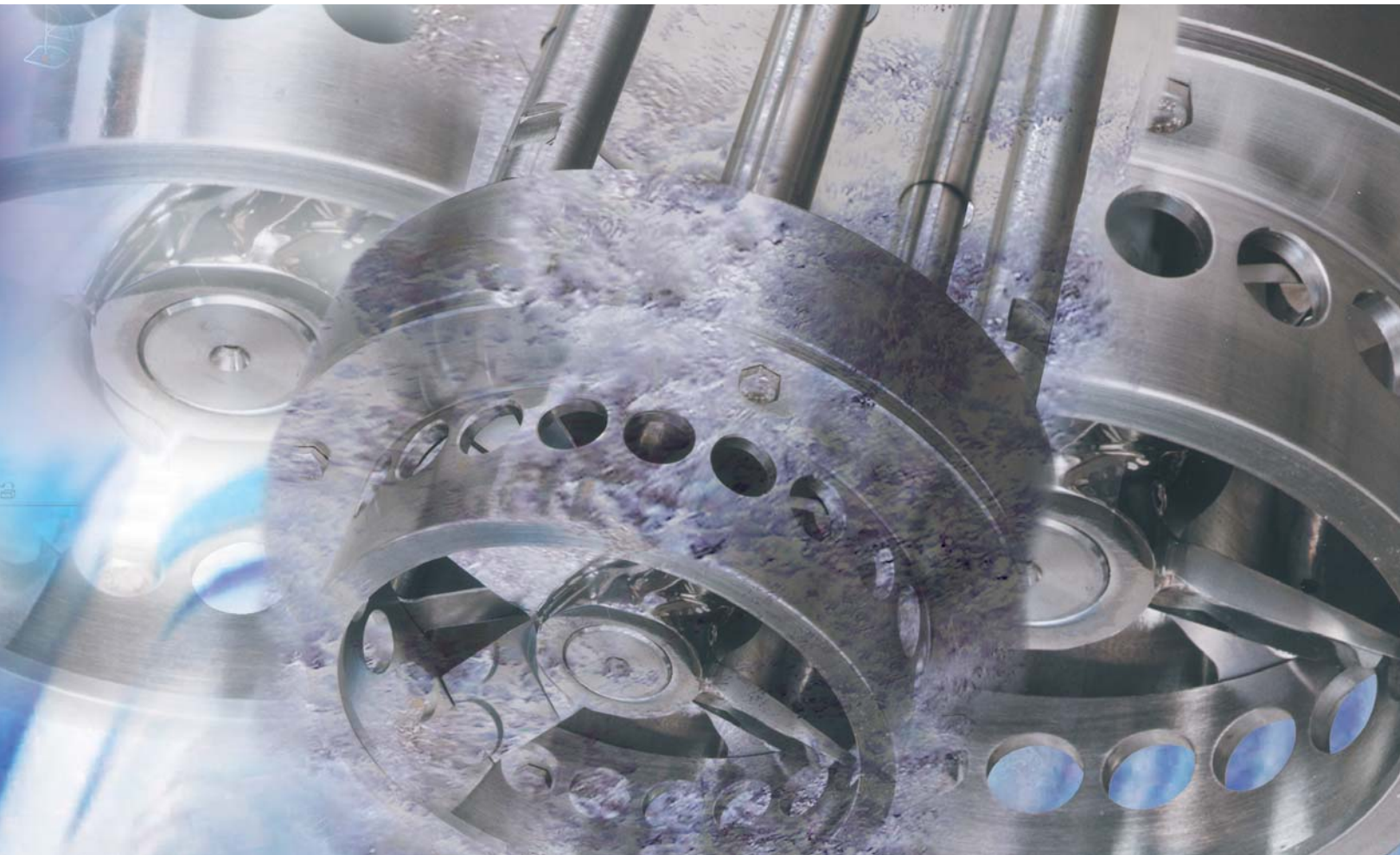

*Greaves high
technology mixers*



the
GM
range

LIST NUMBERS 95 TO 300



High Shear, High Speed Mixers for Industrial Mixing Applications

This brochure illustrates the comprehensive range of Greaves High Shear Mixers, from Pilot Scale Variable Speed Laboratory Mixers with powerful electric motors from 40 watts to 550 watts, or alternatively pneumatic motors.

The production models offer a comprehensive range from 180 watts to 75kw with simple free standing lifts to pneumatic or hydraulic lifts available on models up to 15kw. Models up to 18.5kw are available with lifting slings for change vessel use and all can have mounting flanges for permanent mounting on the process vessel, either open or closed, topped with mechanical seals where required. All Mixers are available to a wide range of standards.

Most High Shear Mixers operate on a purely centrifugal displacement caused by the rotating impeller and this displacement gives promotion to flow. The Greaves High Shear Mixer utilises a positive action impeller and liquid is positively drawn into the mixer head rather than relying on centrifugal displacement. This positive flow is clearly indicated when comparing flow capacities at elevated viscosities. Greaves High Shear Mixers will operate at viscosities in excess of 30 Pas.

The particle size can be controlled by the size of the discharge ports in the stator, finer ports achieving finer dispersion or globular size in emulsions.

Greaves High Shear Mixers have a comprehensive range of discharge port sizes, some of which have the capability of emulsifying to 3 micron depending on the product. These when fitted do, however, reduce the mass flow promoted by the mixer and it may be necessary to install a larger than normal mixer to promote adequate flow or add a secondary impeller to circulate the batch.

The other key advantage of Greaves High Shear Mixers is the adjustable deflector plate which models up to 30kw can be operated whilst the mixer is in use. When raised, axial as well as radial liquid flow is promoted in the mixing vessel, however this does reduce the quantity of product being exerted to high shear, but does give a high level of surface movement and as the liquid being processed is drawn from the base of the vessel the possibility of aeration can be eliminated. Many applications have been found where the mixers are used to de-aerate products.



CONTENTS

Page 4/5	Batch Model Range
Page 7	Bottom Entry Mixers
Page 8	Inline Mixers
Page 9	Laboratory Mixers
Page 6	Mixer Stands
Page 3	Specification Details



Emulsifying

The high shear action connected with high upward flow rate maintains the immiscible liquids in full circulation whilst they continue to be passed through the mixer head. Excellent emulsions can be produced with the minimum effort. Oil in water and water in oil emulsions are rapidly produced even when thickening has taken place; the high flow rate permits any colouring to be added at the end of the batch.

Homogenising

The mixer will homogenise most emulsions without making any physical changes to the mixers and after a period of time a stable emulsion will be produced.

Solubilising

The mixers have proved their success over many years preparing Methyl Cellulose, Carboxy-Methyl Cellulose, Locust Bean Gums, Starch Ethers and Esters, Alginates and Crystal Gums for stabilising of foodstuffs and as thickening agents. Even when the viscosities rise to 30,000 cps the standard mixer will circulate the designed capacity, and will disperse any lumps which may have formed due to poor addition.

Diluting

Due to the high suction produced by the mixer, heavy pastes or sediments which may have formed are instantly dispersed.

Disintegration

The rigid construction of all Greaves mixers has contributed greatly to their success, particles are reduced rapidly with the minimum of effort, the high shear impeller connected with the powerful sucking action reduce particles in the minimum time.

Reliability

Their heavy duty construction provides reliable and long lasting service, including a Greaves Mixer built in 1947 still in operation.

Health and Safety

The Greaves High Shear Mixers are available with a limited range of specifications to meet the ever demanding Health and Safety requirements, including the ATEX standards.

Viscosity

The Rotor/Stator mixing principle provides the most efficient method of blending and emulsifying of a wide range of viscosities which may be encountered in a single batch.

Continuous Mixing

To compliment our range of Batch Mixers we offer 1.5kW to 30kW inline, or continuous High Shear Mixers which include all the features available to the production range of mixing equipment.

Industrial Applications

Abrasives | Adhesives | Asphalt | Bakeries | Bitumens | Breweries | Biochemicals | Canned Fruit | Cement Slurries | Ceramics | Chemicals
Clays | Crayons | Coal Tar | Confectionery | Cosmetics | Drugs | Dyestuffs | Dairies | Detergents | Disinfectant | Effluent Treatment
Essences | Emulsion Paints | Epoxy Resins | Flavours | Food | Fertilizers | Gelatines Gums | Glue | Inks | Latex Compounds | Oil Blending
Paints | Paper Sizes | Paper Coating | Perfumes | Pesticides | Pharmaceuticals | Pigments | Plastics | Preservatives | Polishes | Resins
Rubber | Sauces | Soft Drinks | Starches | Soap Synthetic Latexes | Tanneries | Textile Binders | Thickeners | Toiletries | Varnishes
Water Treatment | Wallpapers



Production Batch Mixers

List No 95

Construction

The heavy construction of Shear Stators minimises the possibility of "wear out disintegration".

Seal Systems

All Mixers are available with a comprehensive range of shaft seals to meet a wide range of pressure, vacuum and temperature applications.

Impeller

The Impellers, having one of the most efficient angled blades, provide a positive input to shear stator and are capable of handling liquids with viscosities in excess of 30 Pas. For abrasive applications, the Impeller and Shear Stator can be hardened for extended life.

Adjustable Baffle Plate

This controls the height of circulation and has a manual control rod on models up to 30kw (1440rpm). In many processes the liquid level rises and by adjusting the height of the Baffle Plate, excellent top to bottom liquid movement can be maintained without adjusting the mixer.

1. Flow Pattern with the Baffle Plate raised

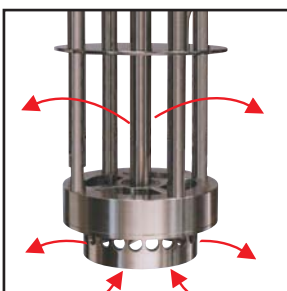

2. Flow Pattern with the Baffle Plate lowered

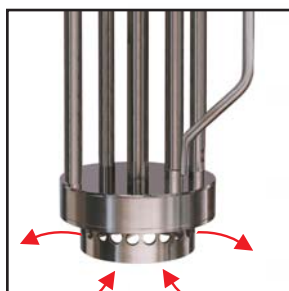

Shear Stators

A full range of Shear Stators are available and include the general purpose emulsification head, the cutting/disintegration head and the wedge wire head. The latter on several occasions, being used to replace a more expensive multi-head homogeniser.

General Purpose



Slotted Head



Emulsifier



Cavitation Capability

The diagrams illustrate the unique advanced high shear mixers reverse flow pattern. In reverse, the deep vortex formed can be used to draw powders from the liquids surface, giving excellent wetting properties without the need for a secondary impeller.

3. Flow Pattern with the Impeller reversed

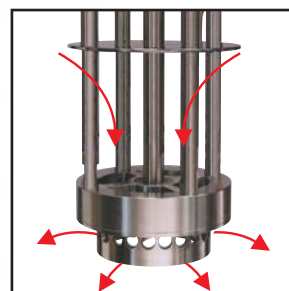

Production Batch Mixers

List No 95

All Production Mixers are fitted with single speed motors as standard, but two speed are readily available at a small extra cost. Hazardous motors to ATEX standard are available. Most models are also available with variable speed if required using either a mechanical variator, inverter frequency speed controller, pneumatic or hydraulic drive.

List 130 GM40 to 60

These mixers operate at 1000rpm offering quiet running and long life reliability on larger mixers. 1,000L to 18,000L.

Larger models are available and details can be forwarded on application.

GM5 to GM20

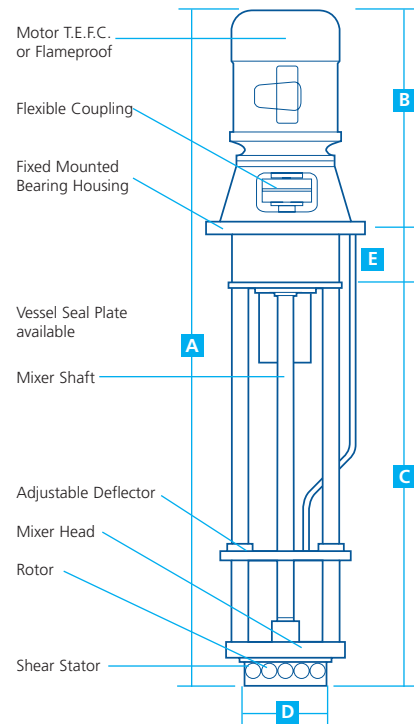

GM1/4 to GM3

List 95

Model	KW	Speed	A	B	C	D	E	F	G	H	J	K	Weight	Capacity
GM1/4	0.18	3000	745	280	465	90	45	292	241	51	102	12	14.5 kg	10-80 litres
GM 1/2	0.37	3000	860	300	560	125	45	292	241	51	102	12	29.5 kg	20-150 litres
GM3/4	0.5	3000	1065	300	765	125	45	292	241	51	102	12	30 kg	30-200 litres
GM1	0.75	3000	1230	340	890	125	100	292	241	51	102	12	32 kg	50-350 litres
GM2	1.5	3000	1230	340	890	125	105	292	241	51	102	12	34 kg	75-500 litres
GM3	2.2	3000	1370	370	1000	162	100	381	330	102	152	18	48 kg	150-900 litres
GM5	4	3000	1580	550	1030	162	40	350	305	120	160	14	70 kg	200-1400 litres
GM10	7.5	3000	2490	690	1800	232	40	470	410	180	240	19	165 kg	700-3000 litres
GM15	11	3000	2605	805	1800	232	40	470	410	180	240	19	220 kg	1800-4500 litres
GM20	15	3000	2605	805	1800	232	40	470	410	180	240	19	225 kg	2200-9000 litres

Note: Dimension C may be shortened or increased according to materials being mixed. C* is available up to 2750mm for types GM15 and GM20. The capacities shown indicate the maximum batch quantity at the maximum viscosity (30 pas) and minimum viscosities. These weights should be checked before making a counter-weight.

List 130

Model	KW	Speed	A	B	C	D	E	F	G	H	J	K	Weight	Capacity
G25	18.5	1500	2650	850	1800	345	45	530	457	457	530	25	430 kg	3150-18000 litres
GM30	22	1000	3500	1000	2500	500	275	760	685	685	760	30	753 kg	3600-22500 litres
GM40	30	1000	3535	1035	2500	500	275	760	685	685	760	30	954 kg	4500-34000 litres
GM50	37	1000	3565	1065	2500	500	275	760	685	685	760	30	1050 kg	6750-45000 litres
GM60	45	1000	3600	1100	2500	500	275	760	685	685	760	30	1120 kg	6750-45000 litres

Note: Dimension C may be shortened or increased according to materials being mixed. All dimensions in millimetres.

Mixer Stands

A comprehensive range of mixer stands either standard or built to customer specifications. The stands can be supplied with manual, hydraulic, pneumatic and electrohydraulic lifts with either mobile or fixed base.

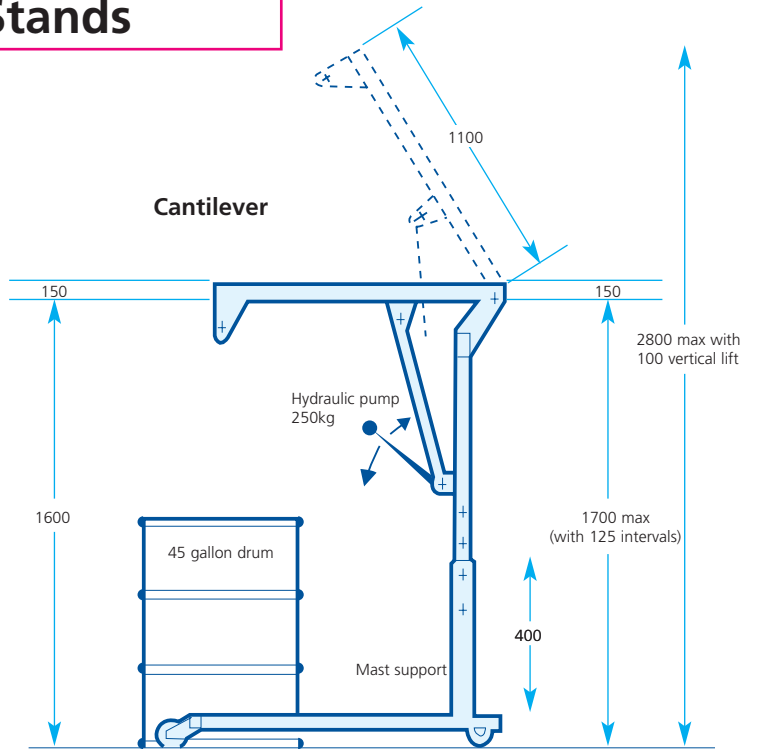
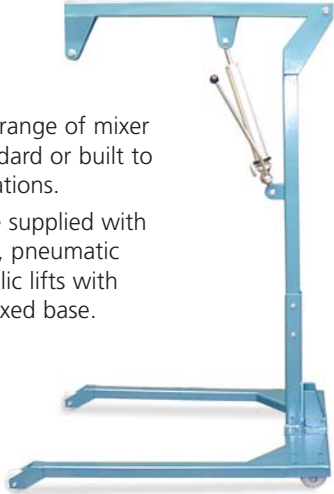

Mixer Stand								
Model	Std Lift	X	A	B	C	D	E	F
GM5	1015	1880	1580	150	990	150	500	300 x 300
GM10	1015	2040	1690	200	1000	150	600	300 x 300
GM15	1270	2450	2075	200	1270	175	760	350 x 500
GM20	1270	2450	2075	200	1270	175	760	350 x 500

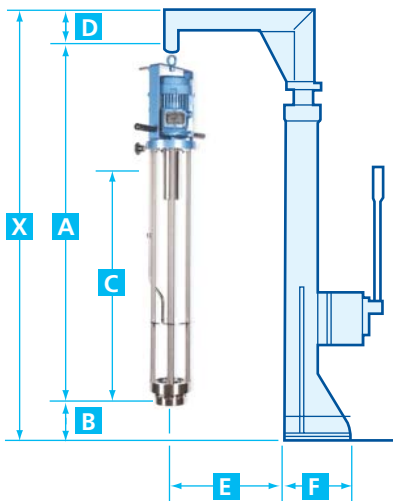
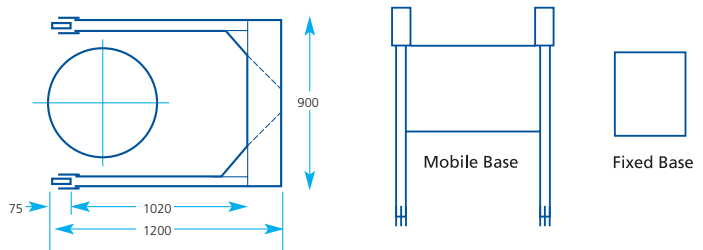

Manual hydraulic lift

Health and Safety Requirement
To comply with the latest Health and Safety requirement, Stand Mounted Mixers will need special safety considerations. This can be discussed with our technical department prior to purchase or installation.

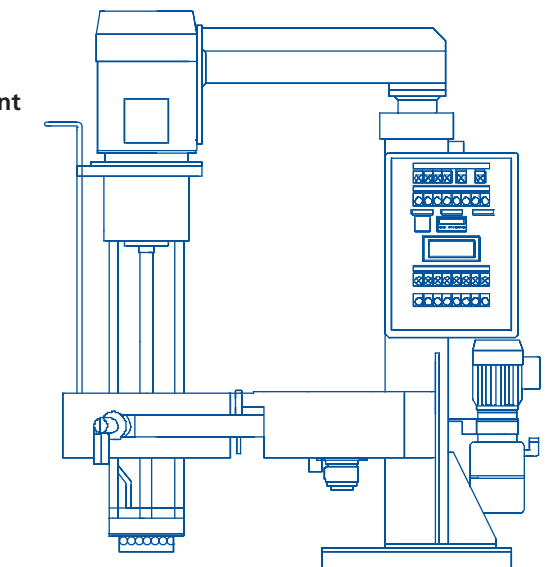

Mixer Stand to comply with HSE requirements

Bottom Entry Mixers

List No 200

Bottom Entry Mixers

Bottom Entry models are designed to be fitted into the base of a mixing vessel. Installation is recommended off centre (see diagram).

The benefits include:-

- The capacity to be used in conjunction with a contra-rotating agitator, or scraped surface gate type stirrers.
- A full range of larger models are available from laboratory size to large industrial systems.
- Aesthetic design and quiet operation.
- Seal leak indication as standard on single seal models.
- Comprehensive seal systems are available for the double shaft seal model.

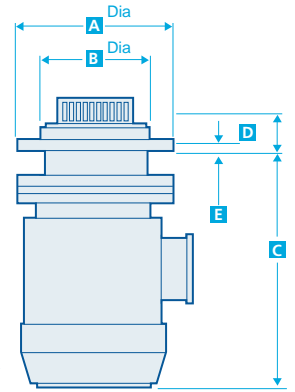
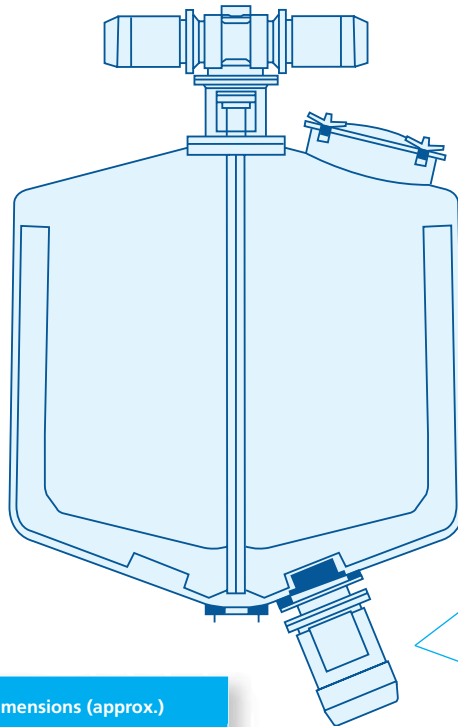

Single mechanical seal

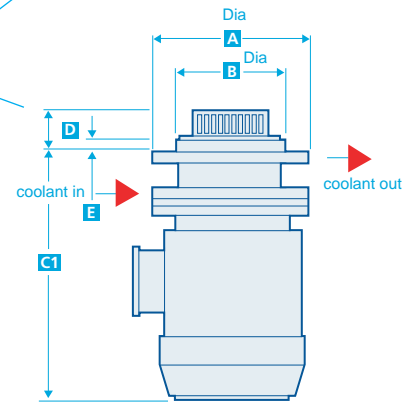

Double mechanical seal

Bottom Entry Mixer	Motor		Dimensions (approx.)							
Size	KW	SPEED	A	B	C	C1	D	E	F	G
BES 2 - BED 2	1.5	3000	215	130	325	365	58	17	14	178
BES 5 - BED 5	4	3000	250	180	385	420	70	20	19	210
BES 15 - BED 15	11	3000	406	260	670	710	82	25	22	356

Shear Stators

A full range of Shear Stators are available

Slotted Head



General Purpose



Emulsifier

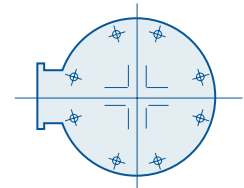

Plan view applicable to all machines



Inline Mixers

List No 300

Inline Mixer & Systems

Designed to either chemical or food industry standards, the inline mixers can incorporate single or double mechanical shaft seal in a range of materials.

The inlet and outlet connections can be supplied to any standard including but not limited to ANSI, RJT and IDF fittings.

The model illustrated is the food industry model with double mechanical seal and polished 316 stainless steel.

The benefits include:-

- Hygienic construction.
- Ease of assembly.
- Various types of Shear Stators available.
- High pumping capacity with low viscosity.
- Aesthetic design and quiet operation.
- Seal leak indication as standard on single seal models.
- Comprehensive seal systems are available for the double shaft seal model.

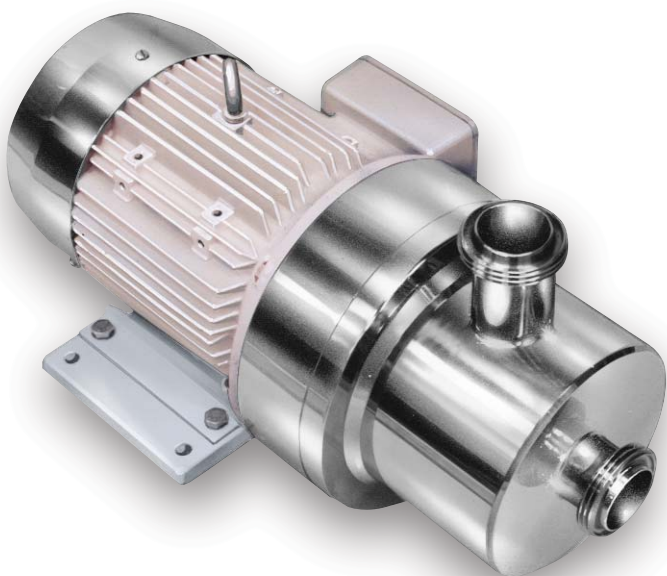

The model illustrated is a food industry standard with a double mechanical seal in polished stainless steel.

Hygienic, Single Mechanical Seal

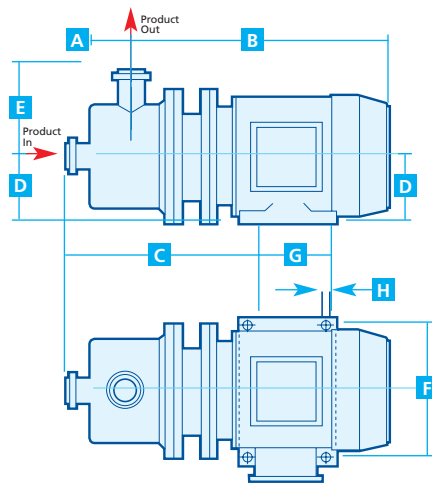

Inline Mixer	Motor		Dimensions (approx.)								Fitting
Size	KW	SPEED	A	B	C	D	E	F	G	H	RJT/IDF
PLMS 1 1/2 x 2	1.5	3000	100	425	310	110	140	200	125	14	38
PLMS 2 x 5	4	3000	120	500	370	127	175	260	140	14	50
PLMS 3 x 15	11	3000	120	700	405	210	250	350	300	19	76

All dimensions in millimetres

Hygienic, Double Mechanical Seal

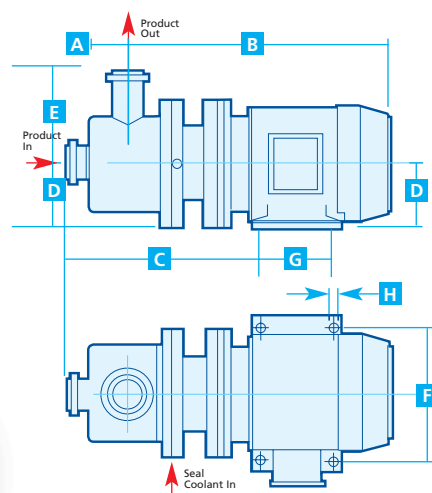

Inline Mixer	Motor		Dimensions (approx.)								Fitting
Size	KW	SPEED	A	B	C	D	E	F	G	H	RJT/IDF
PLMS 1 1/2 x 2	1.5	3000	100	425	310	110	140	200	125	14	38
PLMS 2 x 5	4	3000	120	500	370	127	175	260	140	14	50
PLMS 3 x 15	11	3000	120	700	405	210	250	350	300	19	76

All dimensions in millimetres

Laboratory Mixers

List No 135



Model A 7 litres 40 watt free standing Laboratory Mixer



Model B 2 - 15 litres 90 watt free standing Laboratory Mixer



Model C 5 - 40 180 watt free standing Mixer

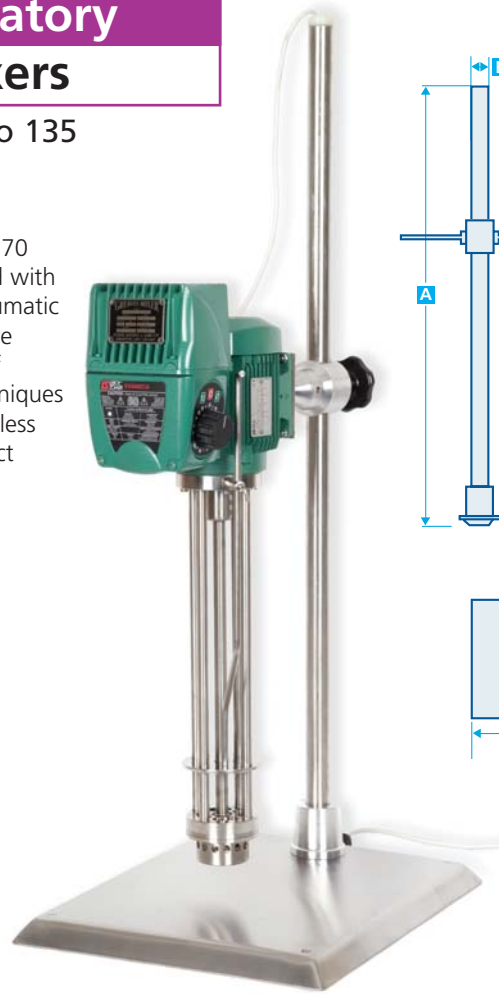

Model D 15 - 90 litres 550 watt floor standing Laboratory Mixer

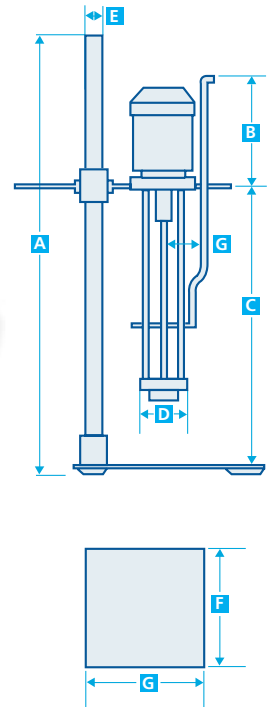

Variable Speed Laboratory Mixer

Model	Varying Speed	A	B	C	D	E	F	G	Weight	Capacity
A	0-8000	457	130	165	43	19	300	240	4.5kg	1-7 litres
B	0-7000	610	165	255	58	25	500	300	6.4 kg	2-15 litres
C	0-7000	685	192	345	70	25	500	300	9.6 kg	5-40 litres
D	0-7000	1067	192	465	90	32	500	300	18 kg	15-90 litres

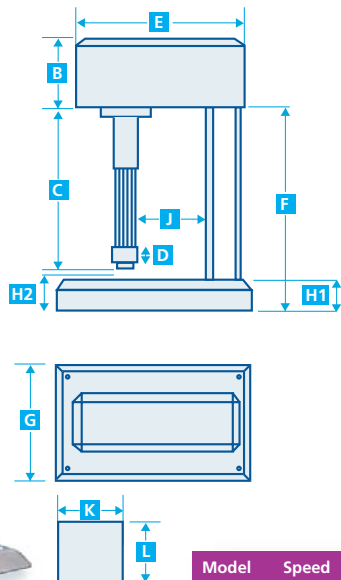

Advanced E.G.M. Laboratory Mixers - List No 235

A range of three recently developed more technically advanced Stainless Steel Mixers for the more demanding research technician.

The benefits include:-

- The high torque electronic variable speed controller.
- A powerful a.c. 190 watt motor with a housing which is located in a single stainless steel enclosure with an integrally mounted control panel.
- A built in reversing switch, which offers a cavitation mixing feature.
- A free standing stainless steel base plate.
- A safety circuit preventing the operator raising or lowering the mixer during the mixing process.
- The option of a built-in 1250 watt heating plate with thermostatic control with a temperature range of 50/320°C.
- Electrical raise and lower control, with 300mm of vertical movements.
- Adjustable timed mixing cycle.
- Digital speed indicator.

Model	Speed	Power Watts	A	B	C	D	E	F	G	H1	H2	J	K	K	L	L	Weight	Capacity
E,G,M,B	0/7000	190	705	180	400	60	430	500	300	25	85	205	100	200	100	200	22	2-15
E,G,M,C	0/7000	190	705	180	400	75	430	500	300	25	85	205	130	200	150	200	22	5-25



JOSHUA GREAVES AND SONS LTD

Atlas Engineering Works, Ramsbotton, Bury, Lancashire BL0 9BG, England

Tel: 01706 824191 Fax: 01706 823000

Email: greavsmixer@btconnect.com Web: www.greaves.co.uk

MANUFACTURERS OF INDUSTRIAL MIXING MACHINES SINCE 1922